

THE INFORMATION CONTAINED IN THIS DRAWING IS THE SOLE PROPERTY OF RYADON INC. ANY REPRODUCTION IN PART OR WHOLE WITHOUT THE WRITTEN PERMISSION OF RYADON INC. IS PROHIBITED.

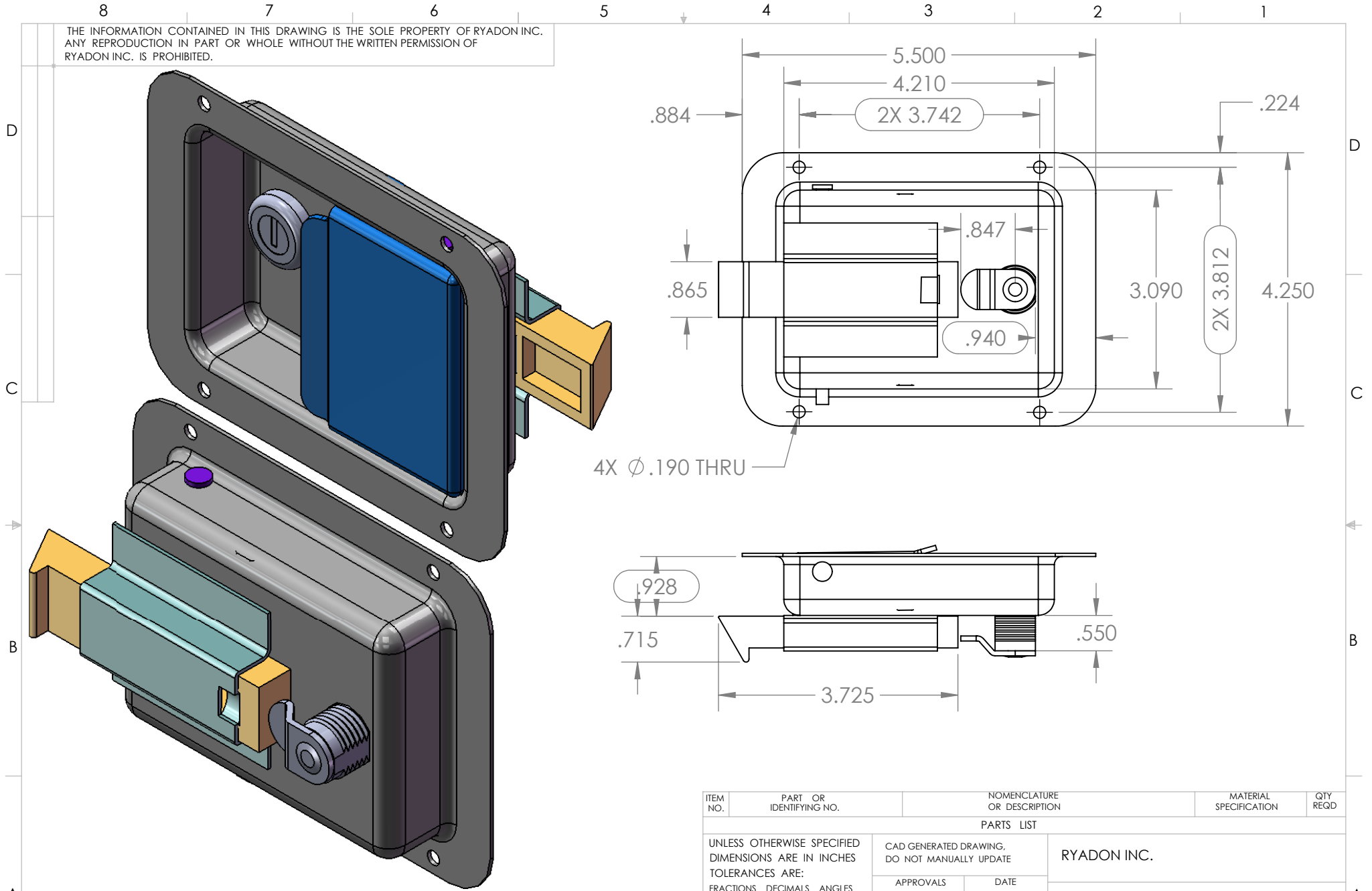

4X Ø .190 THRU

REV	DESCRIPTION	DATE
A	CHANGED POSITION OF LOCK HOLE ON POCKET .120 ON KEY LOCK CHANGED THE LENGHT -.120	7/18/13

ITEM NO.	PART OR IDENTIFYING NO.	NOMENCLATURE OR DESCRIPTION	MATERIAL SPECIFICATION	QTY REQD
PARTS LIST				
UNLESS OTHERWISE SPECIFIED DIMENSIONS ARE IN INCHES TOLERANCES ARE: FRACTIONS    DECIMALS    ANGLES .XX+/- .03    +/- 1 .XXX+.015		CAD GENERATED DRAWING, DO NOT MANUALLY UPDATE	RYADON INC.	
MATERIAL		APPROVALS	DATE	
FINISH		DRAWN	05/22/08	
DO NOT SCALE DRAWING		CHECKED	09/25/13	
		RESP ENG		
		MFG ENG	09/25/13	
		QUAL ENG	09/25/13	
SIZE A	DWG. NO.	PH-9018-L-SS		REV. A
SCALE	CAD FILE:			SHEET 1 OF 2

THE INFORMATION CONTAINED IN THIS DRAWING IS THE SOLE PROPERTY OF RYADON INC.  
 ANY REPRODUCTION IN PART OR WHOLE WITHOUT THE WRITTEN PERMISSION OF  
 RYADON INC. IS PROHIBITED.

ITEM NO.	PART NUMBER	DESCRIPTION	Default/QTY.
1	PH-9018-L-ZN POCKET		1
2	PH-9018-L-SS HANDLE PIN		1
3	PH-9018-L-SS STRIKER		1
4	PH-9018-L-SS STRIKER BRACE		1
5	PH-9018-L-SS HANDLE		1
6	PH-9018-L-SS-KEY LOCK		1

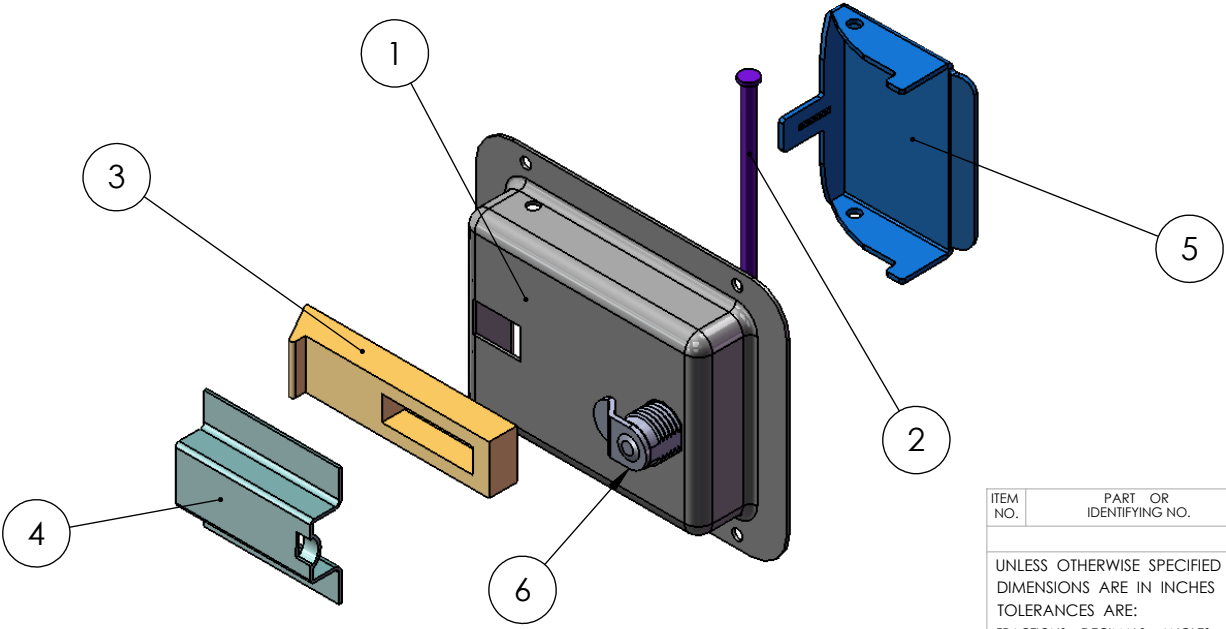

ITEM NO.	PART OR IDENTIFYING NO.	NOMENCLATURE OR DESCRIPTION	MATERIAL SPECIFICATION	QTY REQD
PARTS LIST				
UNLESS OTHERWISE SPECIFIED DIMENSIONS ARE IN INCHES TOLERANCES ARE:		CAD GENERATED DRAWING, DO NOT MANUALLY UPDATE	RYADON INC.	
FRACTIONS	DECIMALS			
---	.XX+/- .03	+/- 1	PH-9018-L-SS BOM	
	.XXX+.015			
MATERIAL	---	APPROVALS		
FINISH	---	DRAWN	05/22/08	
		CHECKED		
		RESP ENG		
		MFG ENG		
		QUAL ENG		
DO NOT SCALE DRAWING		SIZE A	DWG. NO. PH-9018-L-SS	REV. --
		SCALE	CAD FILE:	SHEET 2 OF 2

REV	DESCRIPTION	DATE