

REVISIONS			
REV.	DESCRIPTION	DATE	BY
A	INITIAL RELEASE	8/2/2019	KC
B	ADDED LOGO & UPDATE DIMENSIONS	2/19/2021	KC
C	STANDARDIZED THICKNESS AND HOLES DIA./W/ ±.005 GENERAL HOLES TOLERANCE	8/10/2022	KC

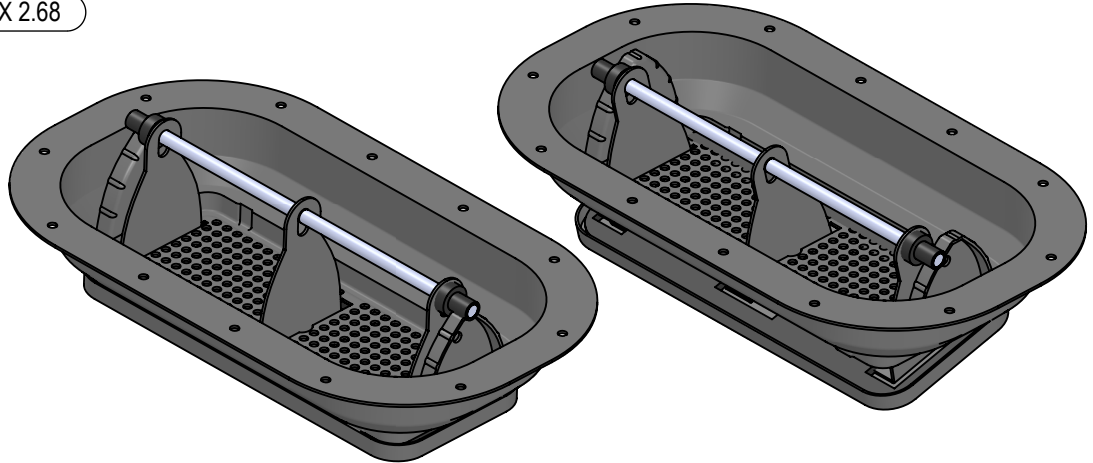
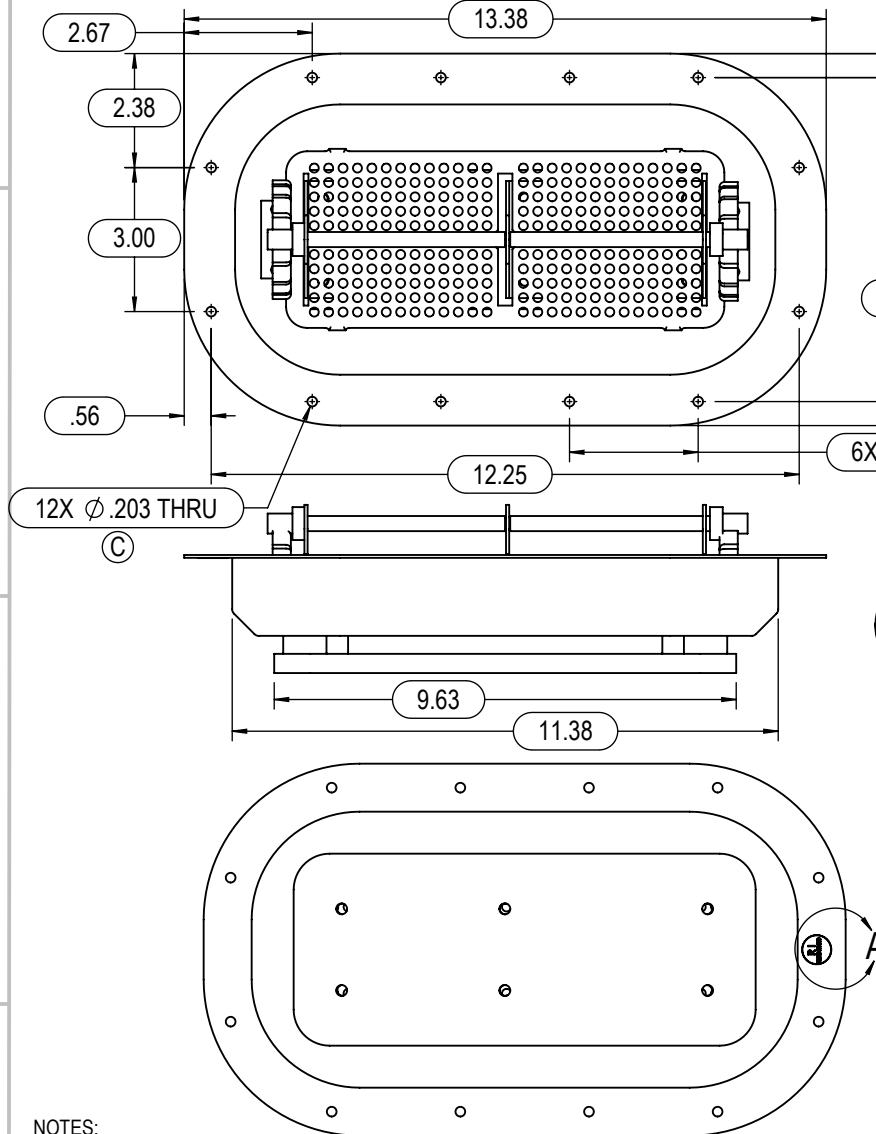

PART NUMBER:	RV-626-050	MATERIAL:	STEEL
DESCRIPTION:	ROOF VENT, 2 WAY RAISING	FINISH:	BLACK POWDER COAT

# RYADON INC.

UNLESS OTHERWISE SPECIFIED: DIMENSIONS ARE IN INCHES [mm]  ALL HOLES $\phi = \pm 0.005$ [0.13mm] .XX [X] = $\pm 0.03$ [0.8mm] .XXX [XX] = $\pm 0.015$ [0.38mm] .XXXX [XXX] = $\pm 0.0080$ [0.203mm] FRACTIONAL = $\pm 1/32$ " ANGULAR: $\pm 1.0^\circ$	THIRD ANGLE PROJECTION 	SIZE	ENGR	SALES	QUALITY	REV
		<b>A</b>	KCHEN	BW	PN	<b>C</b>
		DATE	2/4/2021	8/10/2022	8/10/2022	
		SCALE: 1:4	DO NOT SCALE		SHEET 1 OF 1	

- NOTES:
- DIMENSIONS APPLY AFTER FINISH.
  - DO NOT SCALE DRAWING.
  - BREAK ALL SHARP EDGES AND REMOVE ALL BURRS.
  - MUST HAVE NO SCRATCHES, DINGS, DENTS OR SURFACE IMPERFECTIONS OTHER THAN SURFACE FINISH REQUIREMENTS.
  - CRITICAL DIMENSIONS ARE INDICATED BY: C
  - TO BE INSPECTED TO 2.5 AQL SAMPLING PLAN UNLESS OTHERWISE STATED.
  - ENSURE PACKAGING WILL PROVIDE ADEQUATE PROTECTION DURING TRANSPORT.
  - GEOMETRIC FEATURES NOT DIMENSIONED ARE CONTROLLED BY 3D MODEL.